

system component parts

quantity/ material

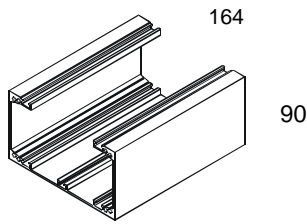

30-7110007
chamber extrusion

5,1 m extrusion
natural anodized
mat silver

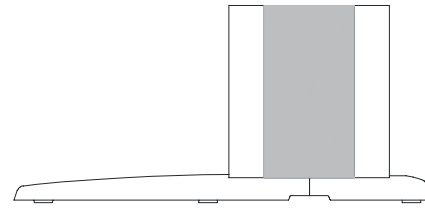

as table foot - single or double chamber extrusion - or
as cable management channel

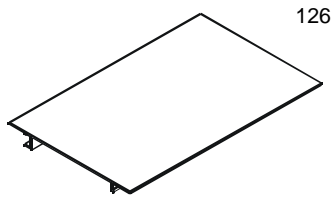

30-7110012
cover for chamber extrusion

5,1 m extrusion
natural anodized
mat silver

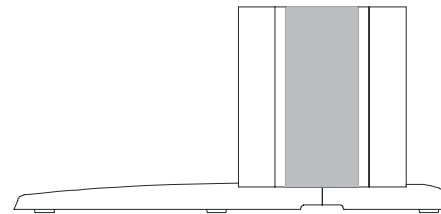

as snap-in cover for chamber extrusion

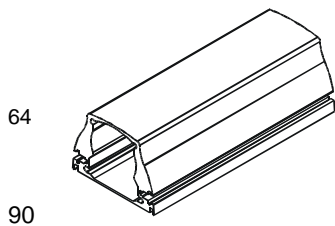

30-7110011
main vertical extrusion

5,1 m extrusion
natural anodized
mat silver

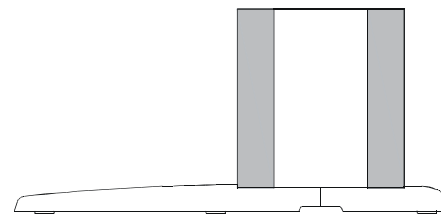

as end extrusion for table feet, in combination with
chamber extrusion, front and rear positioning

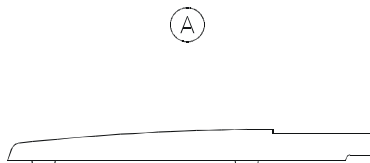

30-7110054
front die-cast runner

1 piece
aluminium die-
cast runner
powder-coated
silver grey

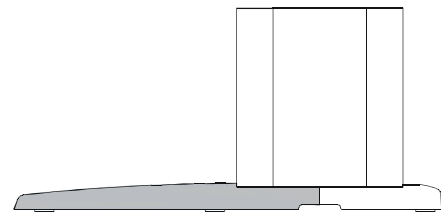

(without levelling feet)

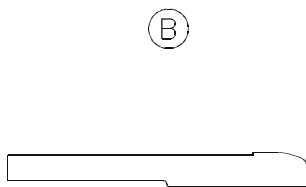

30-7110055
rear die-cast runner

1 piece
aluminium die-
cast runner
powder-coated
silver grey

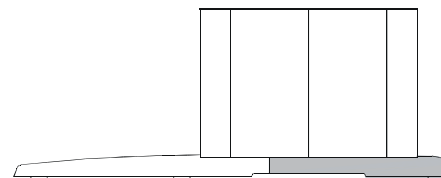

(without levelling feet)

system component parts

quantity/ material

Ⓒ

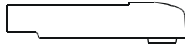

1 piece
aluminium die-
cast runner
powder-coated
silver grey

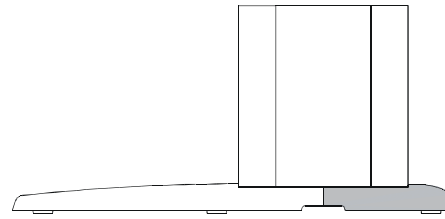

30-7110056
rear die-cast runner short

(without levelling feet)

Combinations of die-cast runners

single columns table foot

double columns table foot

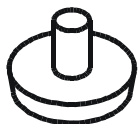
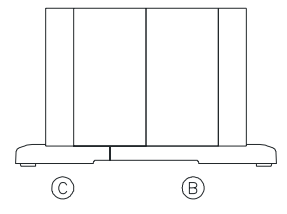
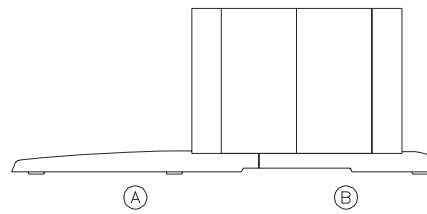
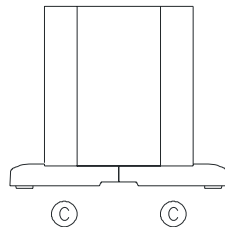
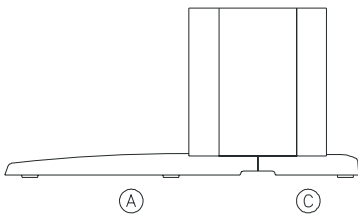

1 set (10 pieces)

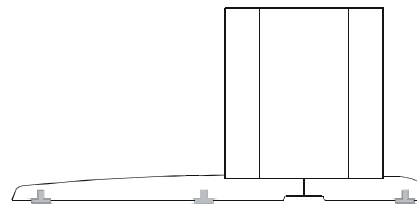

30-1020-00
levelling foot black

3 pieces per runner for precision levelling

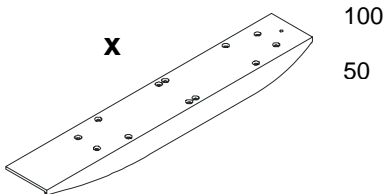

1 pair
aluminium angle
mat silver
anodized

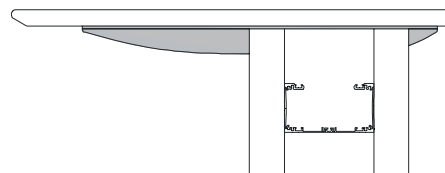

30-7111000
table plate support

to support the table plate
x = length of table plate support, table depth less 150
mm

system component parts

quantity/ material

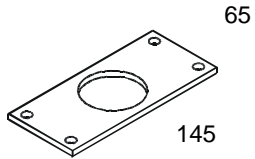
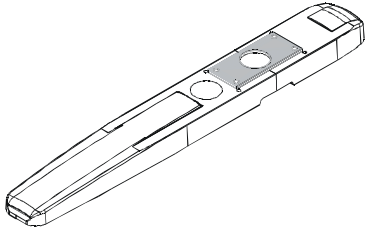
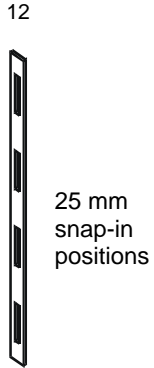
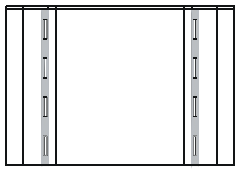
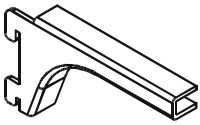
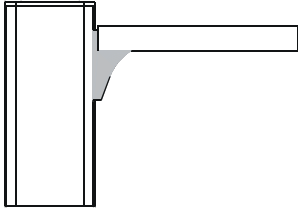
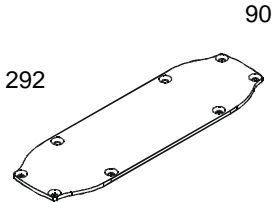
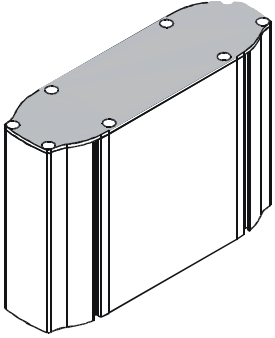
 <p>30-7110100 runner connecting plate</p>	<p>1 piece aluminium bright</p>  <p>to connect two runner elements</p>
 <p>30-7110101 snap-in strip</p>	<p>1 strip special steel 2 mm, length 1.5 m</p>  <p>snap-in strip to slide into side nut of the main vertical extrusion, 30-7110011</p>
 <p>30-71100102 snap-in holder</p>	<p>1 set steel sheet powder-coated silver grey</p>  <p>1 set = 2 pieces, as support for boards to place into snap-in strip</p>
 <p>30-7110103 cover plate for column</p>	<p>1 piece aluminium mat silver anodized</p>  <p>end cover plate for column</p>

system component parts

quantity/ material

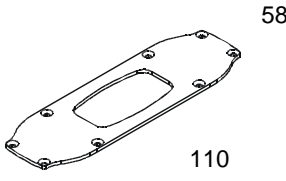
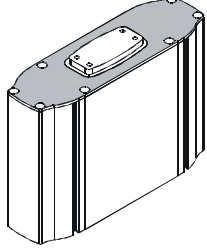
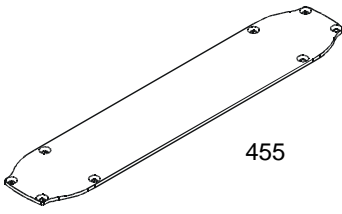
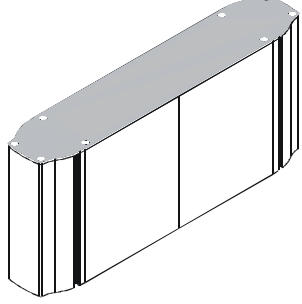
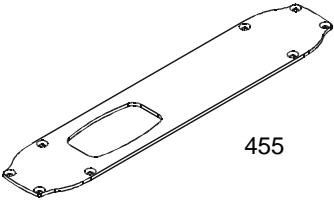
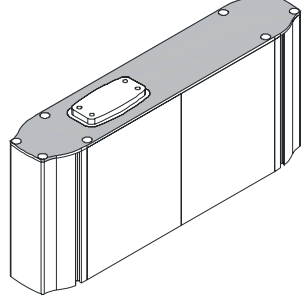
 <p>30-7110104 cover plate for column with cutout</p>	<p>1 piece aluminium mat silver anodized</p>  <p>end cover plate for column with cutout, suitable for electric lift, type DL 4</p>	
 <p>30-7110105 cover plate for double column</p>	<p>1 piece aluminium mat silver anodized</p>  <p>end cover plate for double column</p>	
 <p>30-7110106 cover plate for double column with cutout</p>	<p>1 piece aluminium mat silver anodized</p>  <p>end cover plate for double column with cutout, suitable for electric lift, type DL 4</p>	

Please note:

We shall provide mechanical lifts on request.

system component parts

quantity/ material

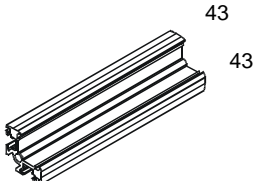
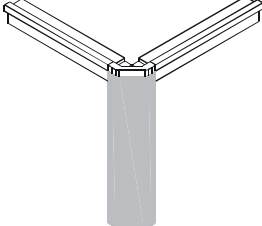
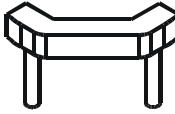
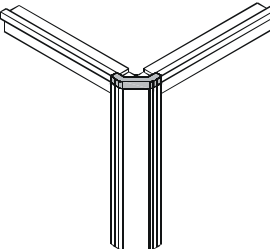
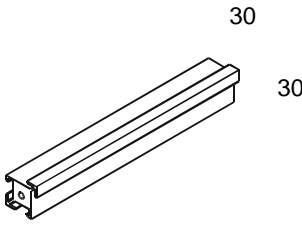
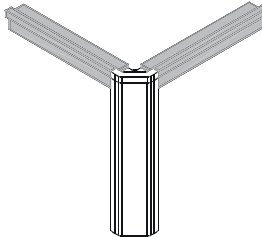
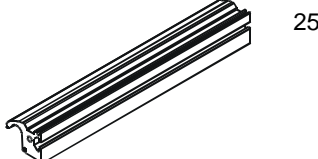
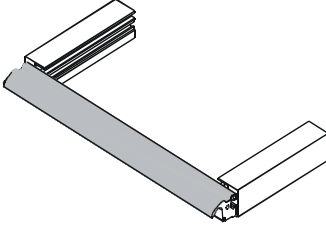
 <p>30-7110002 vertical extrusion</p>	<p>5,1 m extrusion natural anodized mat silver</p>	
 <p>30-1040-01 corner cap</p>	<p>1 piece aluminium natural anodized mat silver</p>	
 <p>30-7110001 horizontal extrusion</p>	<p>5,1 m extrusion natural anodized mat silver</p>	
 <p>30-7110016 lateral extrusion</p>	<p>5,1 m extrusion aluminium blank</p>	

system component parts

quantity/ material

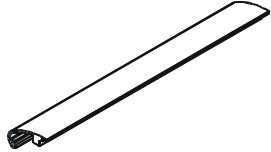
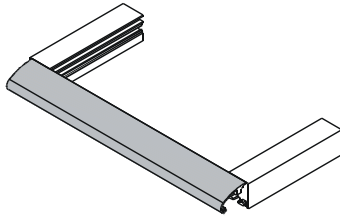
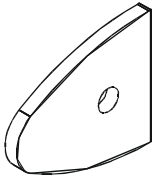
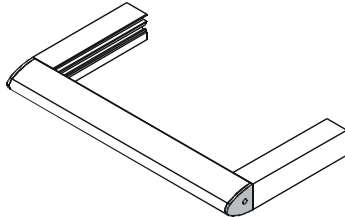
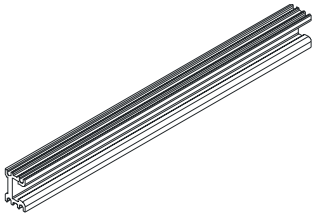
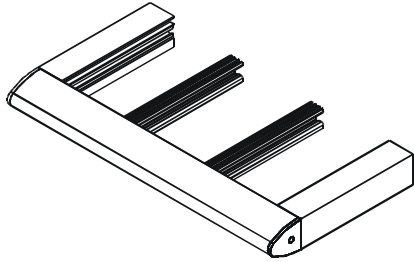
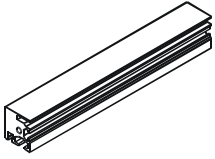
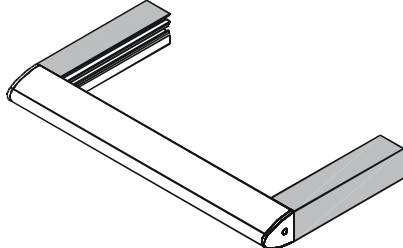
 <p>35</p> <p>30-7110017 cover extrusion</p>	<p>5,1 m extrusion natural anodized mat silver</p>	 <p>swivelling extrusion to cover lateral extrusion, system component of the inclinable operating surface</p>
 <p>30</p> <p>30-1040-00 end cover cap</p>	<p>1 piece diecasting powder-coated silver grey</p>	 <p>end cover cap for cover and lateral extrusion, system component of the inclinable operating surface</p>
 <p>14</p> <p>30-7110018 supporting extrusion</p>	<p>5,1 m extrusion natural anodized mat silver</p>	 <p>supports surface plates at the joints, system component of the inclinable operating surface</p>
 <p>27</p> <p>30</p> <p>30-7110019 side extrusion</p>	<p>5,1 m extrusion natural anodized mat silver</p>	 <p>side extrusion of the operating surface system component of the inclinable operating surface</p>

system component parts

quantity/ material

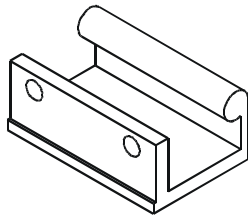

30-7110021
hinge extrusion

5,1 m extrusion
aluminium
natural anodized
mat silver

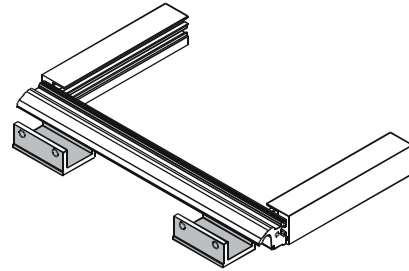

functions as hinge in combination with lateral extrusion,
system component of the inclinable operating surface

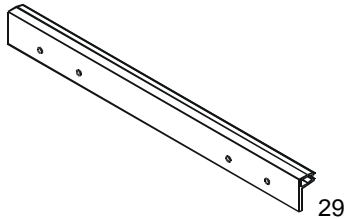

30-7110020
brush holding extrusion

1 piece
aluminium
natural anodized
mat silver

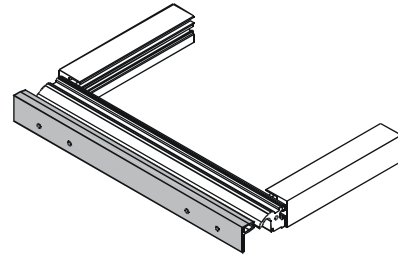

brush to be slit into brush holding extrusion,
system component of the inclinable operating surface

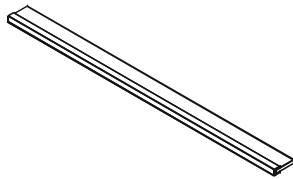

30-7110022
brush profile

1 m profile
synthetic
brush black

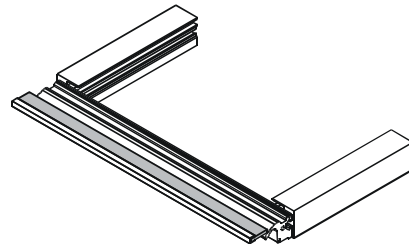

to slide into brush holding extrusion,
system component of the inclinable operating surface

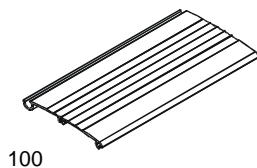

30-7110040
back panel extrusion

5,1 m extrusion
aluminium
natural anodized
mat silver

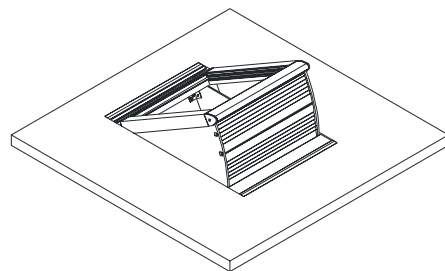

back panel extrusions can be connected to form a radiused back panel,
system component of the inclinable operating surface

system component parts

quantity/ material



30-1050-00
retractable slide

1 pair
galvanized
including
mounting
material

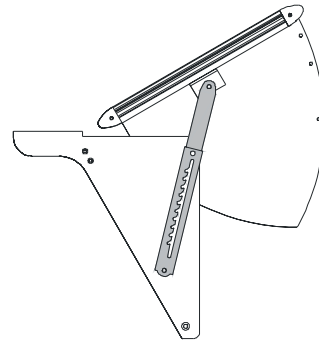

tilt function of the operating surface, position can be adjusted 10 times,
system component of the inclinable operating surface

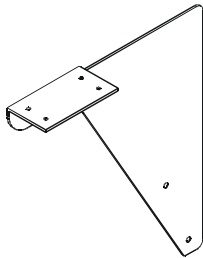

30-7120322
supporting sheet (right and left)

1 pair
steel sheet
silver grey
power-coated

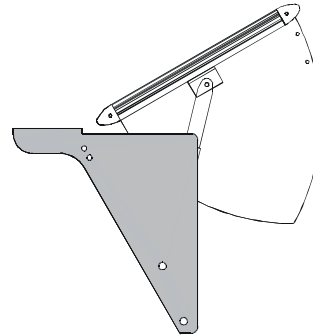

retractable slides mounted to supporting sheet,
supporting sheet mounted underneath the table plate,
system component of the inclinable operating surface

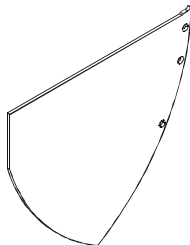

30-7120400
side panel (right and left)

1 pair
MAX-HPL
colour according
to colour chart

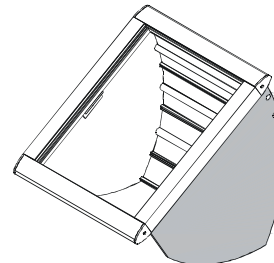

side panels of the com-desk operating surface,
system component of the inclinable operating surface

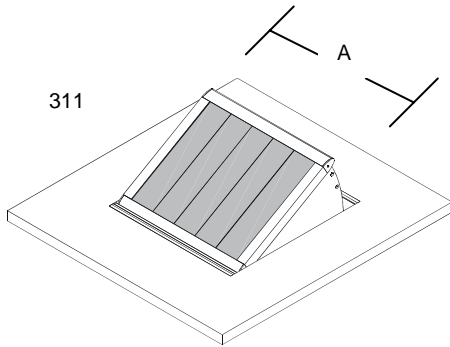

com-desk operating surface:

can be angled between 0° and 60°,
front panels are held in alternate frame (tool-free access),
operating surface can be released ahead to enable access to equipment and cables

cutout dimensions of the table plate:

	d	x	w
1.	444,2	x	489 mm
2.	444,2	x	849 mm
3.	444,2	x	1281 mm
4.	444,2	x	1641 mm

(A) width

- 1. 488 mm 6 x 72 front panel
- 2. 848 mm 11 x 72 front panel
- 3. 1289 mm 17 x 72 front panel
- 4. 1640 mm 22 x 72 front panel

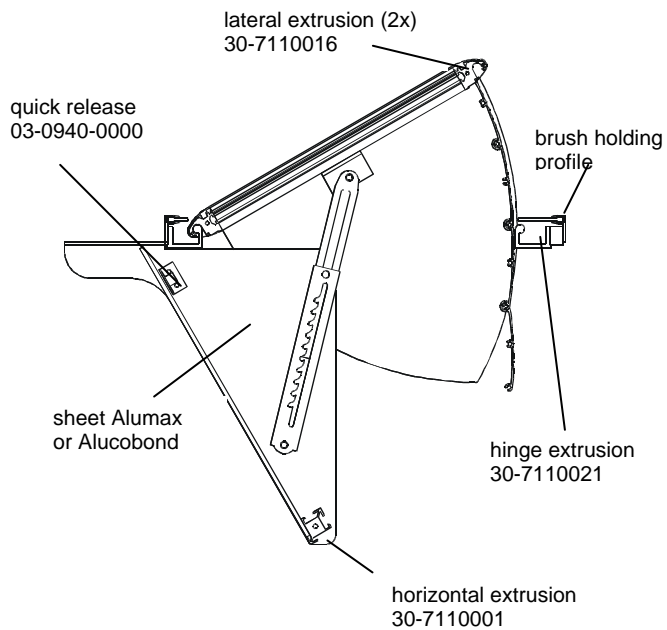
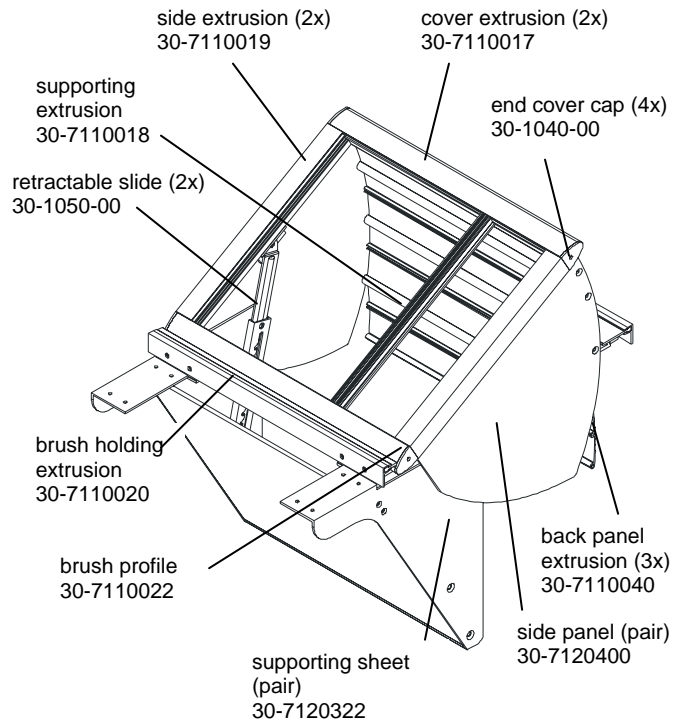

- 30-810-0006**
- 30-810-0011**
- 30-810-0017**
- 30-810-0022**

system component parts

quantity/ material

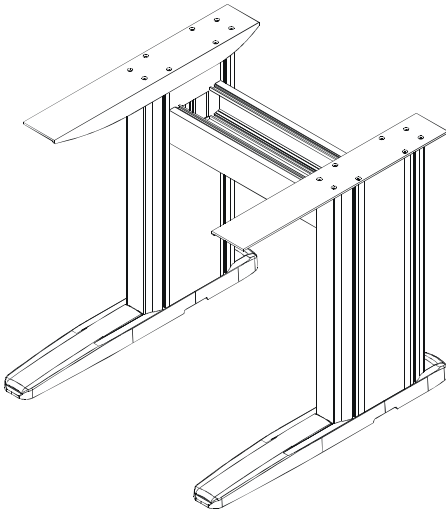

extrusions:
aluminium
anodized mat
silver
runners:
silver grey
powder-coated

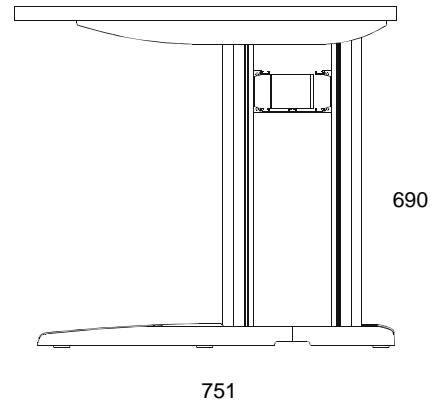

com-desk
underframe, column **FIX**

pre-assembled mounting kit

for table plates (w x d)
800 x 800 mm
1200 x 800 mm
1600 x 800 mm
2000 x 800 mm

30-800 / 0800
30-800 / 1200
30-800 / 1600
30-800 / 2000

integrated cable management,
removable cover for chamber
extrusion,
runners with levelling feet

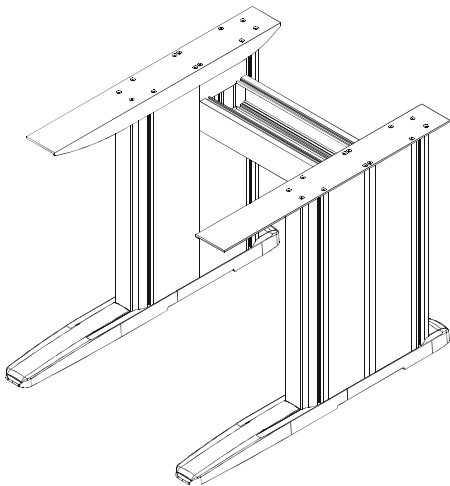

extrusions:
aluminium
anodized mat
silver
runners:
silver grey
powder-coated

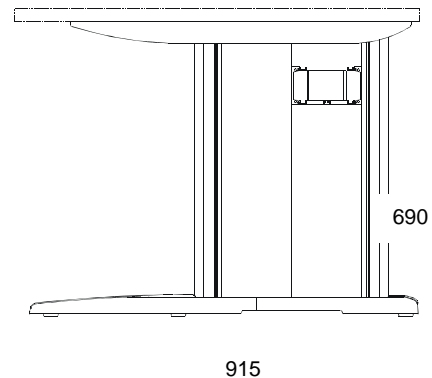

com-desk
underframe, double column **FIX**

pre-assembled mounting kit

for table plates (w x d)
800 x 960 mm
1200 x 960 mm
1600 x 960 mm
2000 x 960 mm

30-801 / 0800
30-801 / 1200
30-801 / 1600
30-801 / 2000

integrated cable management,
removable cover for chamber
extrusion,
runners with levelling feet,
for deeper table plates and heavy
loads

system component parts

quantity/ material

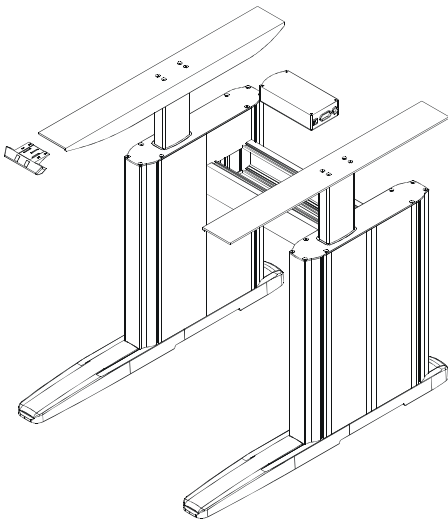

extrusions:
aluminium
anodized mat
silver
runners:
silver grey
powder-coated

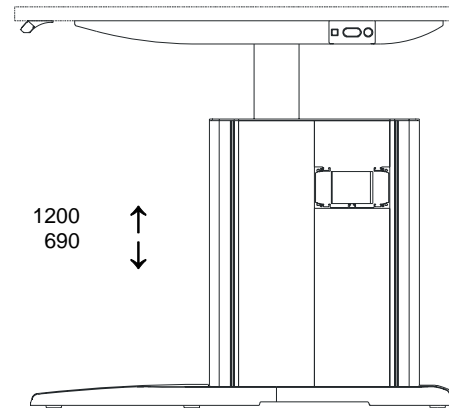

com-desk
underframe, double column
sitting/ standing work place

pre-assembled mounting kit

for table plates (w x d)
800 x 960 mm
1200 x 960 mm
1600 x 960 mm
2000 x 960 mm

30-802 / 0800
30-802 / 1200
30-802 / 1600
30-802 / 2000

synchronously operated electric
lift, 700 N per column
including control system, control
box, operating element and
connecting cable

system component parts

quantity/ material

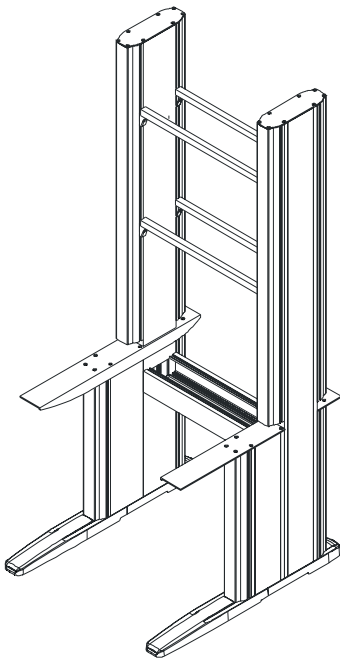

com-desk underframe with monitor boards

for table plates (w x d)
 800 x 900 mm
 1200 x 900 mm
 1600 x 900 mm
 2000 x 900 mm

extrusions:
 aluminium
 anodized mat
 silver
 runners:
 silver grey
 powder-coated

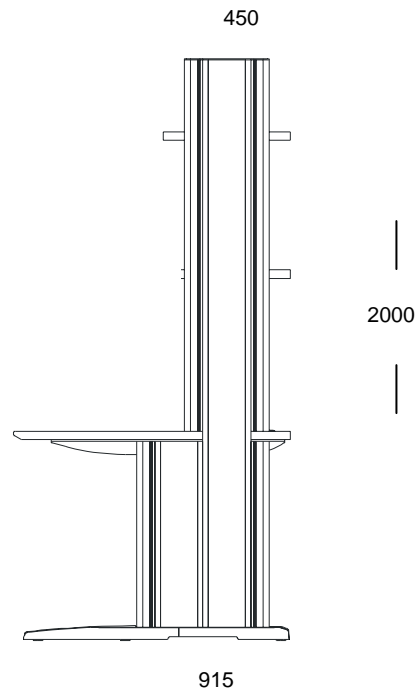
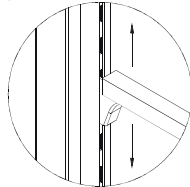

pre-assembled mounting kit

30-803 / 0800
30-803 / 1200
30-803 / 1600
30-803 / 2000

double table columns, two vertical columns,
 integrated cable management,
 removable cover of chamber
 extrusion,
 lateral rails to hold monitor
 boards,
 height-adjustable within the snap-
 in strip

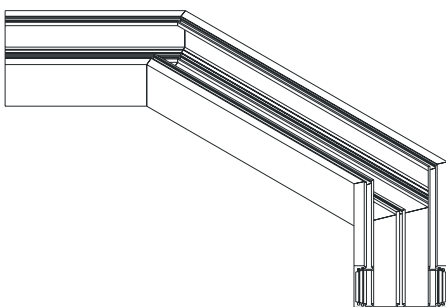

com-desk cable channel, for a rectangular position of the tables
30-720-0090

1 set
 aluminium
 anodized mat
 silver

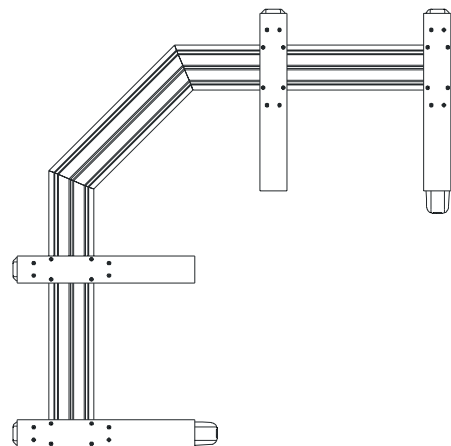

pre-assembled mounting kit, including mounting material

Imprint

Technical changes reserved.

All rights reserved.

Re-print - even in extracts - prohibited unless explicitly permitted in written form.

Errors excepted. Price adjustments subject to change.

Terms of Delivery and Payment:

Lead time: system component parts about 5 working days

system components about 4 to 6 weeks

Delivery: ex works, package and insurance excluded

Payment: 14 days net

Price: All prices stated in EURO.

Ehmki, Schmid & Co.
Mechanische Systeme GmbH
Straßfeld 1
D-85777 Fahrenzhausen

Tel.: ++49/ (0)8133/ 99 645-0
Fax: ++49/ (0)8133/ 99 645-55
email: office@ehmki-schmid.de

www.com-desk.eu